

MECHANIKA MAX II

The new Mechanika MAX II is a decisive step forward in espresso technology with refined control. Designed for easy, faster and more precise espresso experience built for everyday excellence.

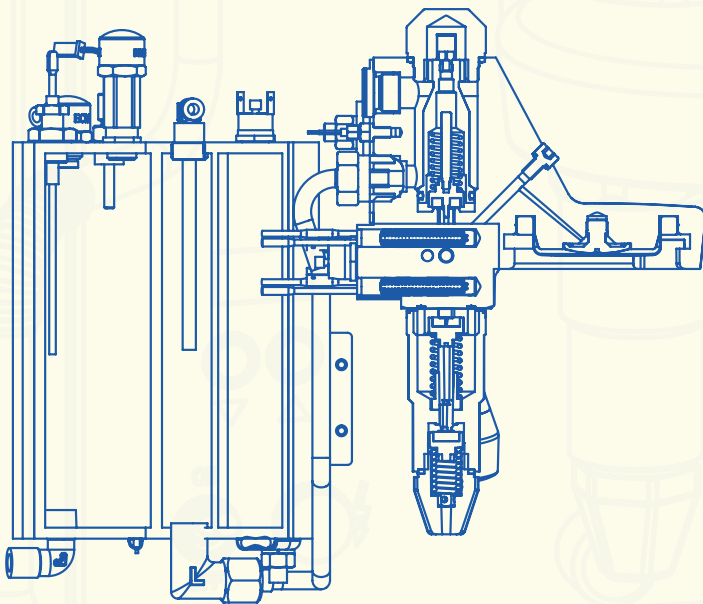

BTC System

The integrated BTC System (Brew Temperature Control) enables precise temperature adjustments between each extraction. Combined with the advanced heated group head and optimized boiler layout, ensuring excellent thermal stability and precision in every cup.



Advanced one-way HX system to reduce thermal fluctuations.



The cartridge-heated group head ensures superior thermal stability.



Precise temperature control enables adjustment within 1°C.



Fast Heat-Up Time

Ready to brew in just 12 minutes thanks to an advanced group head with cartridge heaters

OLED

OLED Control Display
Programmable pre-infusion, timers, and cleaning alerts, total control at a glance

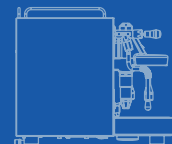
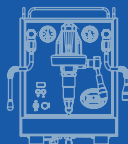
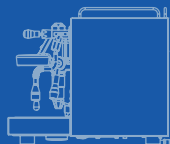

MECHANIKA MAX II

| | |
|--|---|
| Brew group | Cartridge-heated group head |
| Pump type | rotary |
| Fast heat-up mode | 12 min |
| PID controller | • |
| Shot counter | • |
| Timer function | • |
| Valves | Quick steam lever valves |
| Water tank | Approx. 3 l |
| Switchable water tank / fixed water connection | • |
| Automatic water shortage shut-off | • |
| Volume stainless steel boiler | ca. 2 l |
| Boiler pressure gauge | • |
| Pump pressure gauge | • |
| Number of ECM portafilters | 2 |
| Weight | 23.5 kg |
| Item number | CM10028-00 (polished) CM10028-01 (black) |

